

SHACKLES Forged Marine Towing Shackle With Safety Nut and Cotter Pin



**FORGED
MARINE TOWING SHACKLE
WITH SAFETY NUT & COTTER PIN**



LB 301

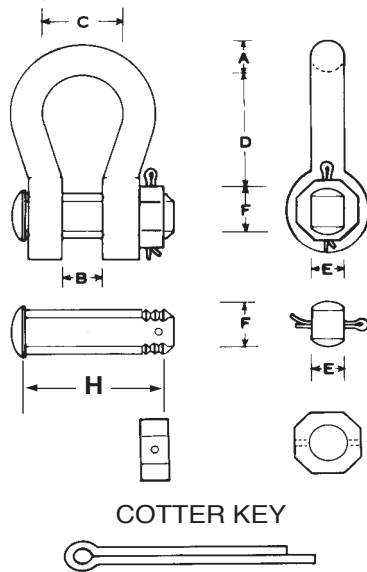
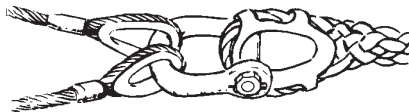

COTTER KEY

LBNO Towing Shackles are primarily designed for the marine towing industry. The wide throat opening and more than generous inside dimensions will allow for the passage of heavy duty hawser thimbles, in addition to the large synthetic rope thimbles normally used in the towing industry. In order to accomplish this with standard shackles, a much larger than needed shackle must be used, thus creating a weight problem in handling for the workmen.

The LBNO shackle is equipped with an oval shaped pin which is stronger than round pins and less likely to deform. The tapered end of the pin is carefully threaded the full width of the nut, eliminating the common problem of galled threads. All pins come with a safety nut secured by a cotter key to prevent backing off due to vibration.

When ordering Always Specify **LBNO Quality Shackles**. All of these advantages have been demonstrated over and over again, by outstanding on-the-job performance.

U.S. PATENT NUMBER 3656293
CANADIAN PATENT NUMBER 939881

Rated Capacity Tons	← DIMENSION IN INCHES →							Weight Pounds Each
	A Size Inches	B Jaw Width	C Width Bow	D Inside Length	E Pin	F Pin	H Pin Lgt.	
30	1 3/4	5 1/8	7	9 3/4	2	2 1/2	11	53
40	2	5 3/4	7 1/2	10	2 1/8	2 7/8	13	74
55	2 1/2	6 1/4	8	10 1/2	2 5/8	3 3/8	15	117 1/2
80	3	7 1/2	9 3/4	13	3 1/4	4 1/8	18	212

- MINIMUM ULTIMATE STRENGTH - 5 times rated capacity.
- Design Rated Capacity Permanently Marked on Every Shackle.
- Average Proof Load is Twice Rated Capacity.
- All shackles furnished proof tested with certificates.