

Towing Plates

Simpler, stronger, and safer—that's the MARQUIP tow plate. Its patented design lets you rig the bridle with only three shackles, eliminating the extra weight, cost, time, and risk of older-style flounder plates. The No. 2 plate features an extra hole for a tandem shackle to tow additional barges, or to haul

in the bridle. Cast from nickel-chrome steel, MARQUIP plates also provide maximum corrosion resistance. They are available in 300,000-, 485,000-, and 624,000-pound pull test capacities, and can be certified on request.

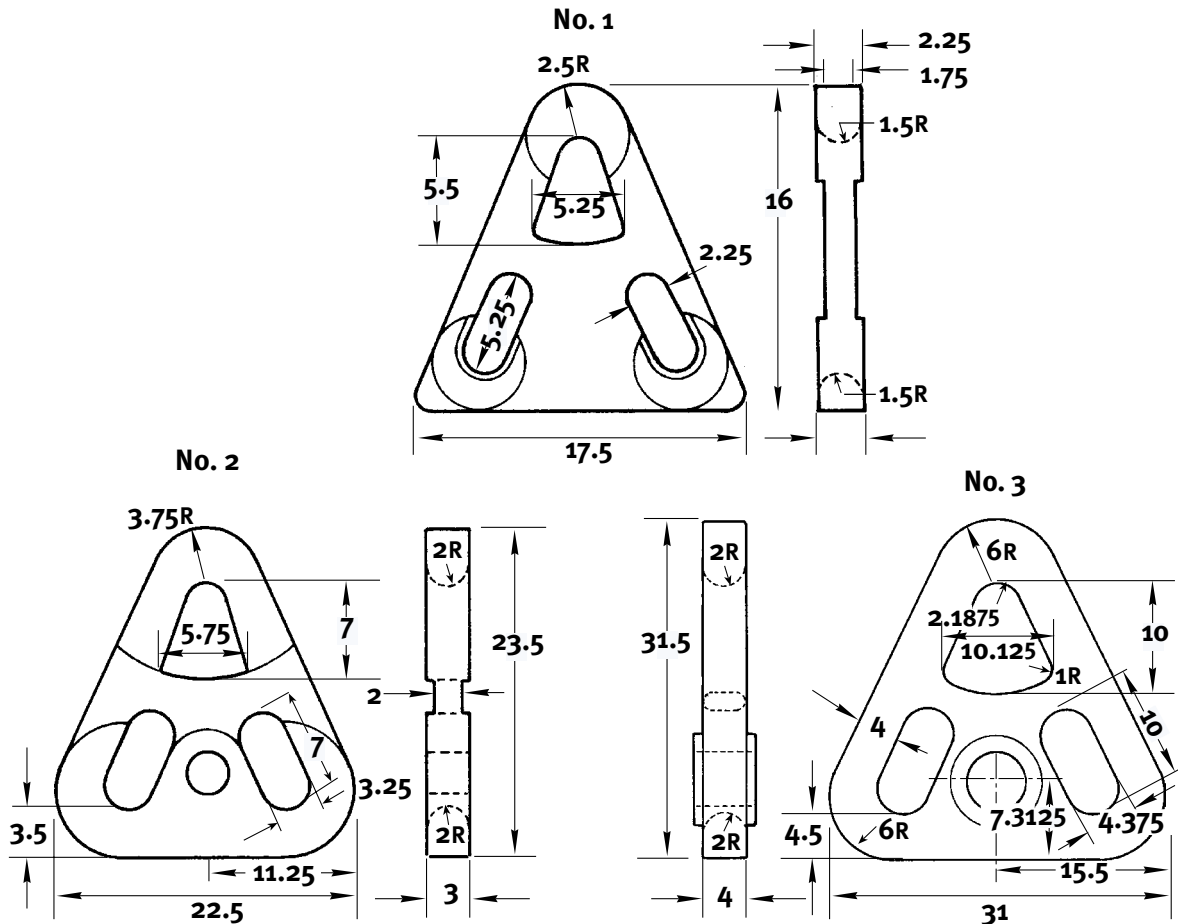

Specifications			
	No. 1	No. 2	No. 3
Shackle	1-1/2	2-1/4	3
Sizes*	1-3/4	2-1/2	4
	2	2-3/4 - 3	
Dimensions	17-1/2 x 16	22-1/2 x 23-1/2	31 x 31-1/2
Weight (lbs.)	70	170	548
Proof Test (lbs.)	300,000	485,000	624,000

*All dimensions in inches